

LATEST INNOVATIONS IN FACADE FRAMING SYSTEMS

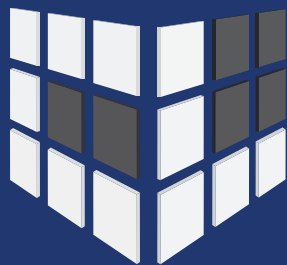

CLAD-LINE[®]

FRAMING SOLUTIONS

FEATURING



FACADE ENGINE[®]
SPECIFICATION BUILDER



www.clad-line.com | +44 (0)1543 222 500 | sales@clad-line.com

CLAD-LINE FRAMING & SUPPORT SOLUTIONS

CLAD-LINE IS ONE OF THE UK'S LEADING MANUFACTURERS OF EXTRUDED ALUMINIUM NON-COMBUSTIBLE SUBFRAME SYSTEMS. WITH OVER 30 YEARS OF EXPERIENCE IN THE MANUFACTURE AND SUPPLY OF RAINSCREEN SYSTEMS, CLAD-LINE HAVE DEVELOPED A COMPLETE SET OF FRAMING SOLUTIONS.

CLAD-LINE aim to simplify the design process, reduce installation time, and provide products which make everybody's life that little bit easier. What better way is there to do this than to work in conjunction with our valued customers and draw upon their first-hand industry knowledge to develop a structurally efficient and fully compliant subframe offering.

Servicing the new build and re clad/refurb markets, the key ethos of CLAD-LINE is innovation. Our team of qualified Design Engineers help to develop innovative solutions to overcome any challenges presented by the most complicated construction projects.

With the aid of CLAD-LINE's state-of-the-art and free to use Facade Engine software, CLAD-LINE can help any customer overcome project specific challenges and provide a comprehensive static calculation for their project requirements. A full Finite Element Analysis is also available to verify the performance of the more bespoke systems.

From the most simplistic but effective rail and bracket system, to the unique Floor 2 Floor framing technology, the CLAD-LINE range offers framing solutions for all design requirements, and can accommodate a diverse range of cladding materials.

CONTENTS

Facade Engine Specification Builder	3
CL1 Subframe System	4
CL2 Subframe System	5
CL3 Subframe System.....	6
CL4 Subframe System	7
F2F Rail System.....	8
CL1-S Soffit System	9
Rails & Brackets	10-12
Environmental	13
Metalline	14
Intelliclad	15

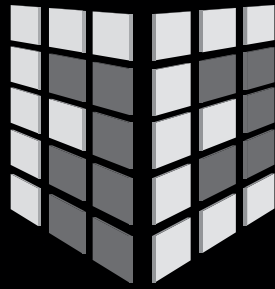

FACADE ENGINE[®]

SPECIFICATION BUILDER

Facade Engine is a state-of-the-art analysis tool for all of your rainscreen subframe requirements. This free to use software provides comprehensive static calculations to help our customers generate the optimum framing design.

- **ANALYSE** internal forces, support reactions and system deflections
- **VERIFY** the analysed forces and deflections are lower than the system resistance
- **OPTIMISE** your framing design by iterating system variables
 - Integrated wind load calculator
 - Fixing analysis and specification
 - Secondary support top hat analysis

Comprehensive analysis of the CL1, CL2 and CL3 bracket and rail systems as well as the unique Floor 2 Floor solution

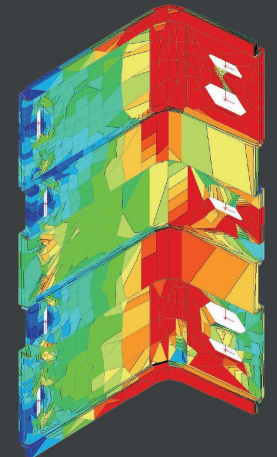

A state-of-the-art analysis tool for all your rainscreen subframe requirements.

CL1

Subframe System

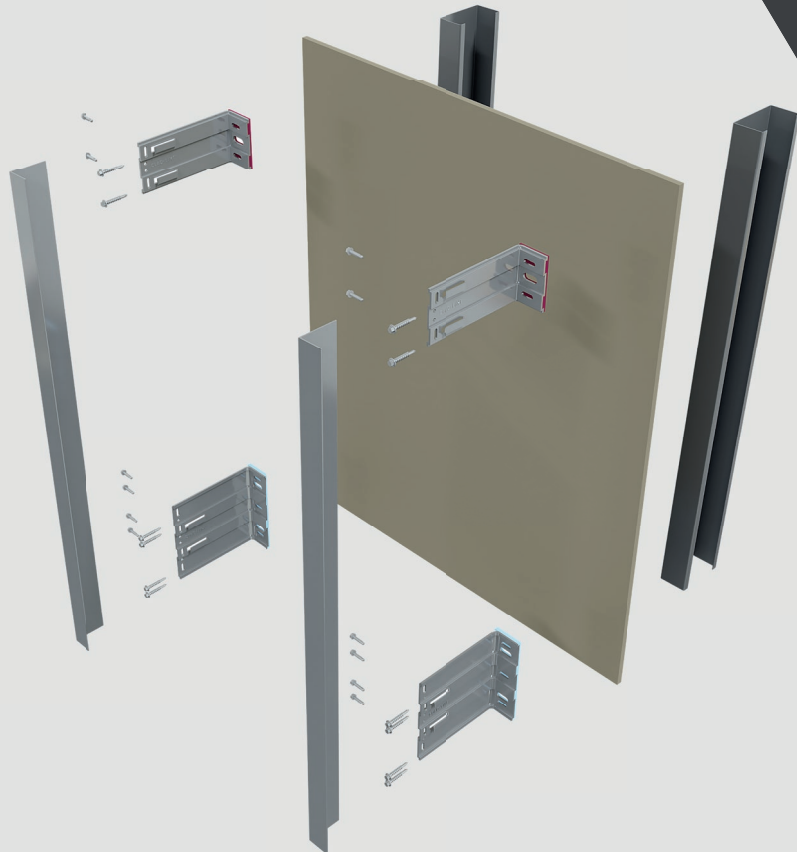

Subframe Systems

- CL1 is suited for a wide range of face fixed and discrete fixed cladding applications.
- Ideal for new build and refurbishment.
- CLAD-LINE's T and L profiled rails are fixed using the CL range of support brackets.
- CLAD-LINE's range of support brackets come pre-fitted with a thermal isolation pad. This reduces installation time on site as well as improving the thermal performance of the bracket.



Non-combustible



Powder coated or anodised finishes available on request



Can be fixed back to both stud and masonry



Vertical cladding rails; Horizontal adaptor available



100% recyclable aluminium



Suitable for use with metal rainscreen, Rockpanel, fibre cement, HPL and ACM



Quick and easy to install





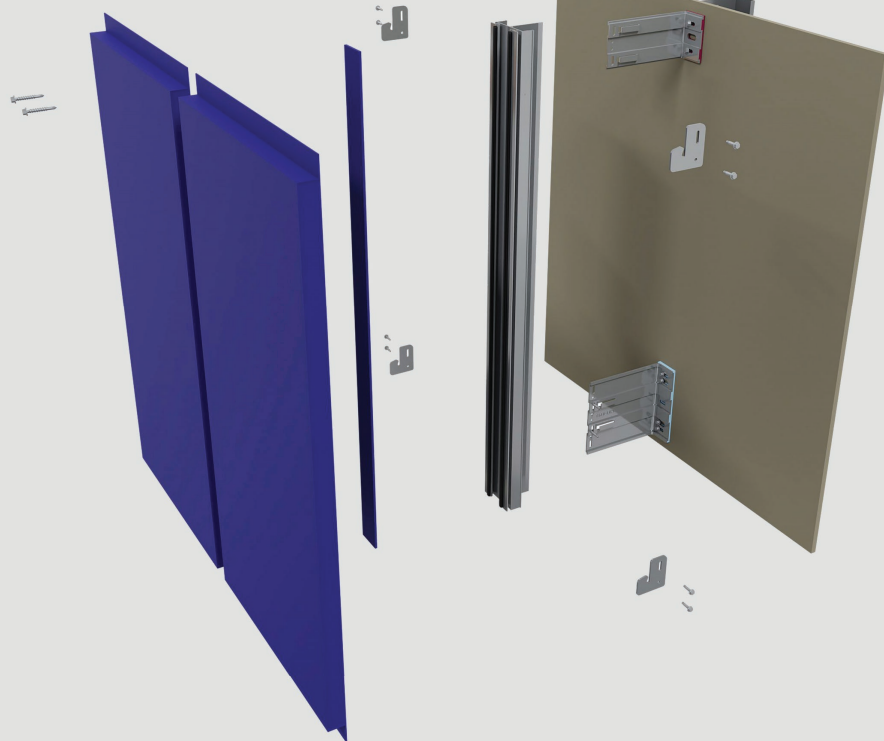

CL2

Subframe System



Subframe Systems

- CL2 is CLAD-LINE's subframe system suitable for supporting secret fixed cassette panels (Aluminium/ Zinc / ACM).
- The panel is secured using specially designed cassette hangers to provide the secret fix. The CL2 rail also incorporates a robust location for the panel's anti-uplift fixing.
- CLAD-LINE's CL2 rails are fixed using the CL range of support brackets.

-  Non-combustible
-  Provides a secret fix for a metal rainscreen cassette
-  Incorporates a shadow joint cover plate slot
-  High strength, robust rail
-  Quick and easy to install
-  Can be fixed back to both stud and masonry





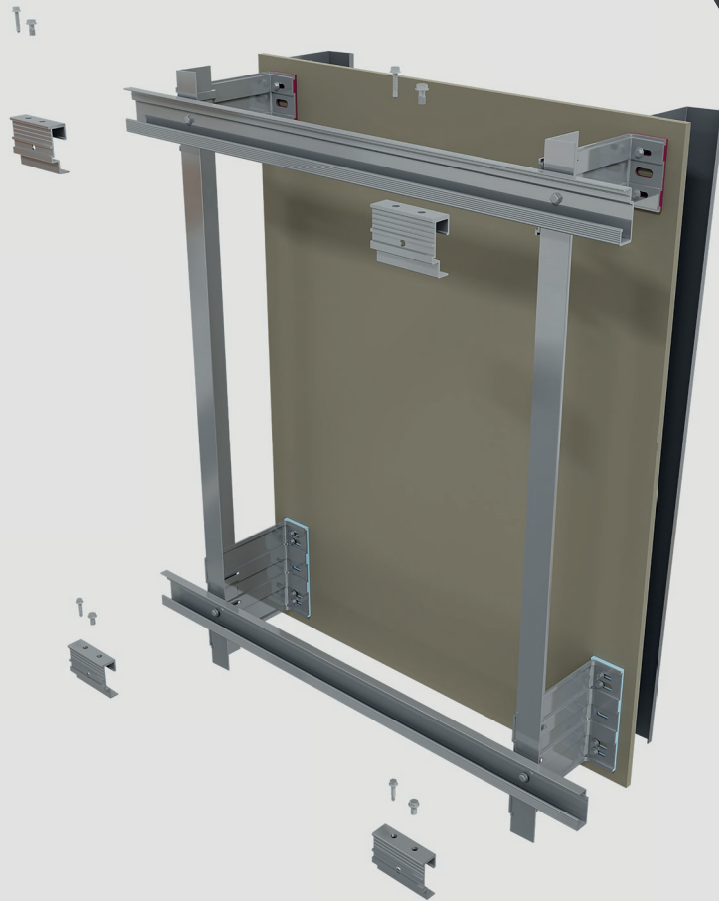

CL3

Subframe System



Subframe Systems

- CL3 is CLAD-LINE's subframe system for mechanically secret fixed applications, suitable for use with Rockpanel, high-pressure laminate (HPL), ceramic, thin stone and fibre cement.
- CL3 panel hangers which are secured to the rear face of the cladding panel simply 'hook-on' to the horizontal rails.
- The CL3 horizontal rails can be fixed back to the CL1, CL4 or CLF2F systems.

-  Non-combustible
-  Suitable for use with Rockpanel, HPL, ceramic, stone and fibre cement
-  Ideal for new build and refurbishment
-  Pre-fitted thermal isolator pad to brackets
-  Hook-on panel installation
-  Adjustable hangers
-  100% recyclable aluminium

CL4

Subframe System

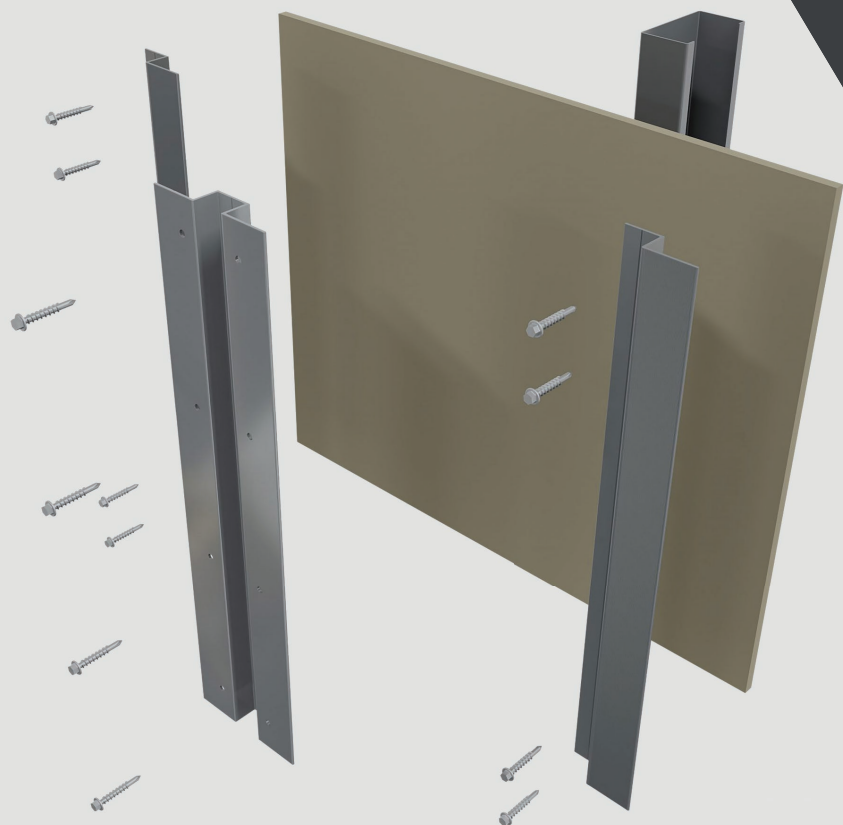

Subframe Systems

- CL4 is CLAD-LINE's non-combustible alternative to timber battens, comprising of Top-Hat and Zed profiles which can be fixed directly back to the main structure. The CL4 system has been designed with oversized flanges to make fixing easier.
- Suitable for rainscreens with a shallow cladding zone (25mm or 40mm), this system can be used with a wide range of face fixed cladding panels.



Non-combustible



Suitable for use with Rockpanel, HPL, ceramic, stone and fibre cement



Ideal for new build and refurbishment



Faced fixed panel installation



Cost effective installation



Cavity range from 25mm to 40mm







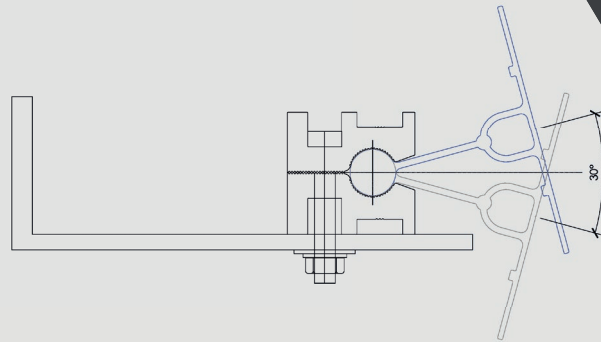
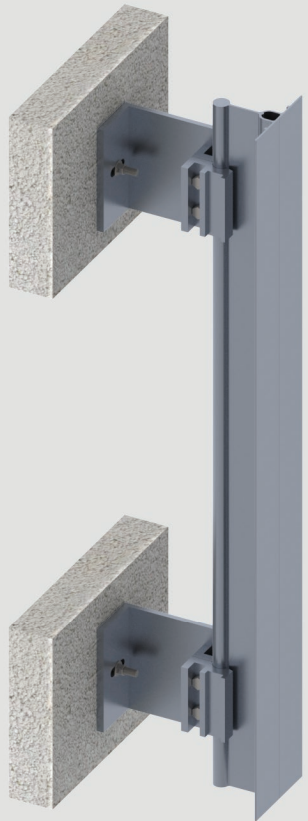

100% recyclable aluminium

F2F FLOOR FLOOR Rail System



Subframe Systems

- CLAD-LINE'S F2F system has been designed to accommodate, flat, discrete-fix and hook-on Rainscreen Panels and is fully compliant with all types of A1 and A2 facade panels including Brick Slip, aluminium, Rockpanel, fibre cement, ACM and terracotta.
- The F2F framing spans from floor slab to floor slab, reducing the requirement for multiple helping hand brackets and supporting top hats.

-  Simplifies design and installation
-  Reduces labour costs
-  Maximum adjustment in all directions
-  Ideal for use with faceted facades
-  Solid Aluminium - Non-combustible
-  Sectional properties available upon request
-  Reduces the amount of fixings required

CL1-S

Soffit System

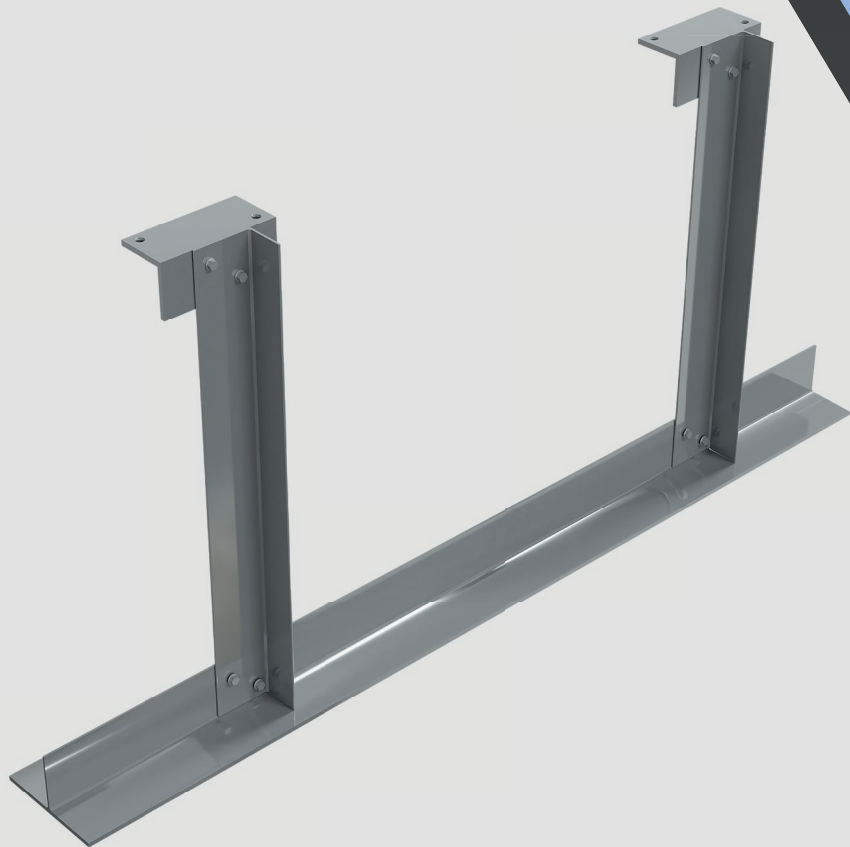

Subframe Systems

- CLAD-LINE'S CL1-S soffit system is suitable for face fixed and discrete fixed soffits.
- Soffits to un-heated areas are frequently not insulated but if thermal bridging is an issue, flat isolation pads can be supplied to limit thermal transmission and prevent bimetallic corrosion.
- T rails are fixed to the bottom of the 'dropper' L rails where panel joints occur. For intermediate and panel end support, CLAD-LINE'S L rails can be used.
- CLAD-LINE hold extensive stock of both T and L rails and can fabricate in house to exact customer requirements. The CL1-S system can also be used to create sloping soffits through cutting of the rails to the required angle.

CLAD-LINE SINGLE SUPPORT BRACKET

Description	Product Code	Range
Single Bracket 90mm	CL-SB90	95-125mm
Single Bracket 120mm	CL-SB120	125-155mm
Single Bracket 150mm	CL-SB150	155-185mm
Single Bracket 180mm	CL-SB180	185-215mm
Single Bracket 210mm	CL-SB210	215-245mm
Single Bracket 240mm	CL-SB240	245-275mm
Single Bracket 270mm	CL-SB270	275-305mm
Single Bracket 300mm	CL-SB300	305-335mm

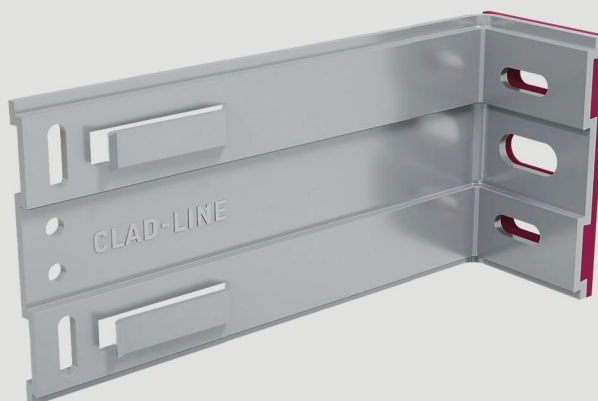

CLAD-LINE DOUBLE SUPPORT BRACKET

Description	Product code	Range
Double Bracket 90mm	CL-DB90	95-125mm
Double Bracket 120mm	CL-DB120	125-155mm
Double Bracket 150mm	CL-DB150	155-185mm
Double Bracket 180mm	CL-DB180	185-215mm
Double Bracket 210mm	CL-DB210	215-245mm
Double Bracket 240mm	CL-DB240	245-275mm
Double Bracket 270mm	CL-DB270	275-305mm
Double Bracket 300mm	CL-DB300	305-335mm

CLAD-LINE SUPPORT RAILS

*Powder Coated & Anodised finishes available on request
*Can be cut to size on request. £tbc

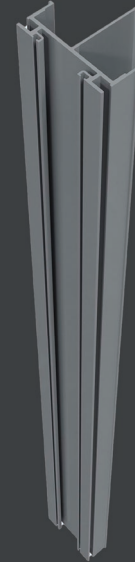

Rails & Brackets

ADDITIONAL PRODUCTS

Description	Product Code
CL1 Horizontal Adaptor 86mm	CL1-HA/86
CL1 Soffit Bracket Standard	CL1-S/BRKT/STD
CL1 Soffit Hanger	CL1-S/HANGER
CL2 Gasket (M)	CL2-GASKET
CL2 Hook	CL2-HOOK
CL3 Hanger Bracket Standard	CL3-H/BRKT/STD
CL3 Hanger Bracket Adjustable	CL3-H/BRKT/ADJ
CL3 Hanger Bracket Fixed Point	CL3-H/BRKT/FP
Single Isolator Pad	CL-SINGLEPAD
Double Isolator Pad	CL-DOUBLEPAD
Single A2 Isolator Pad	CL-SINGLEPAD/A2
Double A2 Isolator Pad	CL-DOUBLEPAD/A2

Description	Product Code
CL1 L Rail 60 x 40 3000mm	CL1-60X40L/3000
CL1 L Rail 60 x 40 6000mm	CL1-60X40L/6000
CL1 T Rail 100 x 60 3000mm	CL1-100X60T/3000
CL1 T Rail 100 x 60 6000mm	CL1-100X60T/6000
CL1 T Rail 100 x 40 3000mm	CL1-100X40T/3000
CL1 T Rail 100 x 40 6000mm	CL1-100X40T/6000
CL1 T Rail 80 x 60 3000mm	CL1-80X60T/3000
CL1 T Rail 80 x 60 6000mm	CL1-80X60T/6000
CL1 T Rail 120 x 60 3000mm	CL1-120X60T/3000
CL1 T Rail 120 x 60 6000mm	CL1-120X60T/6000
CL1 T Rail 140 x 60 3000mm	CL1-140X60T/3000
CL1 T Rail 140 x 60 6000mm	CL1-140X60T/6000
CL2 Rail 3000mm	CL2-RAIL/3000
CL2 Rail 6000mm	CL2-RAIL/6000
CL3 Rail 3000mm	CL3-RAIL/3000
CL3 Rail 6000mm	CL3-RAIL/6000
CL4 Top Hat (120 x 25) 45 x 25 x 35 3000mm	CL4-TH/120X25/3000
CL4 Top Hat (120 x 25) 45 x 25 x 35 6000mm	CL4-TH/120X25/6000
CL4 Top Hat (140 x 40) 55 x 40 x 35 3000mm	CL4-TH/140X40/3000
CL4 Top Hat (140 x 40) 55 x 40 x 35 6000mm	CL4-TH/140X40/6000
CL4 Zed 45 x 25 x 32 3000mm	CL4-ZED/45X25/3000
CL4 Zed 45 x 25 x 32 6000mm	CL4-ZED/45X25/6000
CL4 Zed 55 x 40 x 32 3000mm	CL4-ZED/55X40/3000
CL4 Zed 55 x 40 x 32 6000mm	CL4-ZED/55X40/6000

FLOOR 2 FLOOR PRODUCTS

Description	Product Code
BS Link Bracket 75mm	CLF2F-BS/BRKT/75
BS Link Bracket 100mm	CLF2F-BS/BRKT/100
BS Link Bracket 150mm	CLF2F-BS/BRKT/150
Fixed Point Clip 50mm	CLF2F-Q/CLIP/50
Sliding Point Clip 150mm	CLF2F-Q/CLIP/150
225mm Angle Bracket 75mm	CLF2F-225/ANG/BRKT/75
225mm Angle Bracket 125mm	CLF2F-225/ANG/BRKT/125
Rail Type 1 3000mm	CLF2F-RAIL1/3000
Rail Type 1 6000mm	CLF2F-RAIL1/6000
Rail Type 2 3000mm	CLF2F-RAIL2/3000
Rail Type 2 6000mm	CLF2F-RAIL2/6000
Rail Type 3 3000mm	CLF2F-RAIL3/3000
Rail Type 3 6000mm	CLF2F-RAIL3/6000

CLAD-LINE works with industry leading companies who support our product range with fixings, insulation, fire barriers, pull out testing and A1 & A2 Rainscreen Cladding Panels.

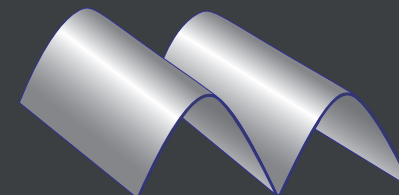

METALLINE[®]
ARCHITECTURAL FABRICATIONS

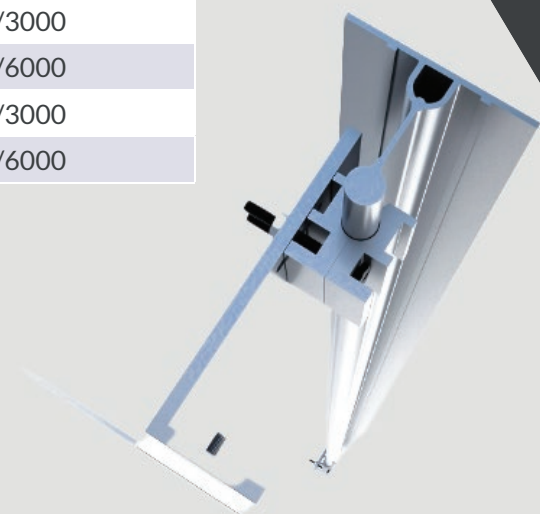

SUSTAINABLE FRAMING SOLUTIONS

At CLAD-LINE we are devoted to ensuring our products are developed to be sustainable enough to last a typical facade's lifetime. We hope our decisions in the design and manufacturing process will lead to a more environmentally friendly future in the cladding industry. Our aim is to eliminate as much waste and pollution as possible, and make our products more environmentally friendly.

CLAD-LINE's systems use Aluminium across the board which means our entire range is 100% recyclable. We have chosen our suppliers not just on their performance to extrude material but their green credentials too. Our systems are manufactured in the UK and use approximately 40% recycled aluminium. Our supplier's ambition is to further increase their share of recycled aluminium and lower CO₂ emission aluminium in percentage to their overall metal requirements by 25% by 2025 from a 2020 baseline, thus increasing CLAD-LINE's share and reducing the overall supply chain CO₂ emissions.

CLAD-LINE ensure wood and cardboard for packing is sourced through local providers committed to responsible sources and waste management, plastic sheeting has a minimum 30% recycled content and pack banding has a minimum of 97% recycled content.

As the world evolves, companies should too. That's why we are striving to minimise our environmental impact through creating our Subframe Systems out of recyclable aluminium.

HELP US BUILD A SUSTAINABLE FUTURE

Our products are as eco-friendly as we believe they can be, yet we are constantly changing. If you have any suggestions on how we can improve our sustainability, please don't hesitate to speak to us.



CLAD-LINE[®]
FRAMING SOLUTIONS

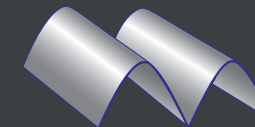

METALLINE[®]
ARCHITECTURAL FABRICATIONS

Made in Britain is a growing community of British manufacturers applying the protected logo's to products, packaging, websites and social media.

CLAD-LINE is proud to promote itself as a British manufacturing company. Made in Britain brings together the British manufacturing community, united with the Made in Britain logo. The Made in Britain logo is Britain's mark of excellence; it helps CLAD-LINE stand proud in the worldwide market and define our pedigree. Being British made has been synonymous with quality workmanship and at CLAD-LINE this is what we offer. Quality British made and British designed products.





Metalline are one of the leading fabricators within the facade industry. Investment in manufacturing equipment and staff training has meant that Metalline continues to grow and deliver quality products to their clients.

Metalline offer a wide range of fire rated aluminium rainscreen cladding panels and facade systems. Perfect for use on a diverse range of construction projects. Our new Unity fire rated cladding system has undergone testing to EN13501-1 and achieved both A1 and A2 - s1,d0 classifications.

www.metalline.co.uk | +44(0)1543 456 930 | sales@metalline.co.uk



ULTIMA

Aluminium Spandrel Panels

UNITY

Aluminium Rainscreen Panels

Metalline also offers the Ultima range of Insulated Spandrel panels which has undergone testing to EN13501-1 and achieved both A1 and A2 - s1,d0 classifications.

The Ultima Insulated Spandrel Panel can be constructed using a range of face finishes dependant upon the classification required, the thickness of the insulation can also be varied to accommodate 'U' values on your project.

Contact us today to discuss your next project and see how we can help you with the complete system.



intelliclad[®]

Smart detection for protection

INNOVATIVE.
RESPONSIVE.
COST-EFFECTIVE.

Intelliclad is a wireless system certified to EN54-25 which is designed to be integrated into the external facade of high-risk buildings where combustible materials are present.

The system uses smart sensors which are fitted inside the cladding system and are connected to a control system so that in the event of a fire, an alert can be sent to all residents via sounders, a unique smartphone app and the main alarm system within the building, in compliance with BS 5839-1 L5.

Our intelligent system uses a cloud-based technology to give residents and the fire service valuable information on the location of the fire and its relative spread across the building due to its ability to monitor the situation in real time. Each sensor is aware of its exact location and can therefore provide precise information as to where on the facade the fire is located.

www.intelliclad.co.uk | www.linkedin.co.uk/company/intelliclad





CLAD-LINE[®]
FRAMING SOLUTIONS

CLAD-LINE Framing Solutions
Unit 4, Primary Point, Progress Drive, Cannock, Staffordshire, WS11 0JF
www.clad-line.com | +44 (0)1543 222 500 | sales@clad-line.com